

橡胶手套输送链 Rubber gloves carrier chains

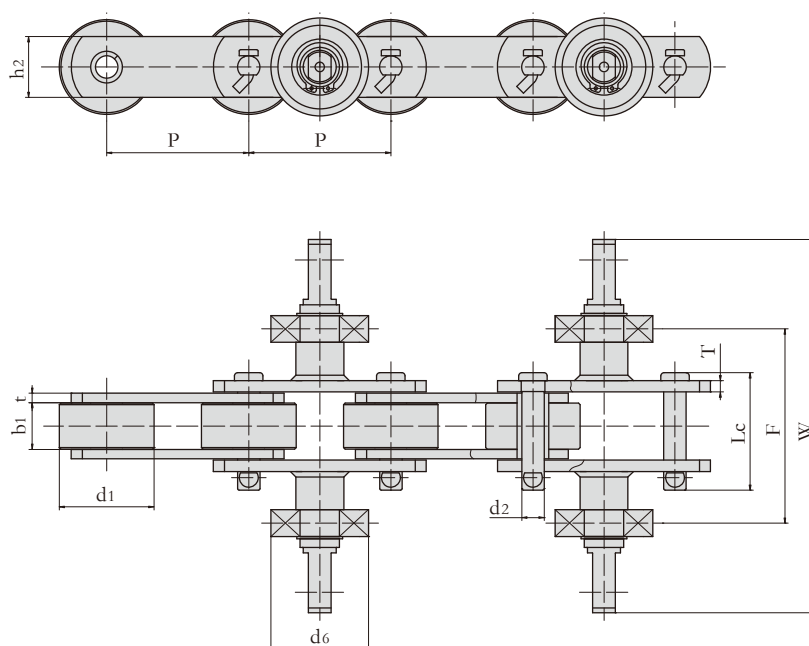

| 东华链号 Donghua Chain No. | 节距 | 滚子直径 | 内节内宽 | 销轴直径 | 销轴长度 | 链板高度 | 链板厚度 | 附件尺寸 | | | 抗拉强度 |
|------------------------------|-------|-----------------|----------------------------|--------------|------------|-------------|-----------------|----------------------|-------|------|------------------|
| | Pitch | Roller diameter | Width between inner plates | Pin diameter | Pin length | Plate depth | Plate thickness | Attachment dimension | | | Tensile strength |
| | p | d1 max | b1 min | d2 max | Lc max | h2 max | t/T max | F | W | d6 | Q min |
| | mm | mm | mm | mm | mm | mm | mm | mm | mm | mm | kN/bf |
| P90F1 | 90.0 | 60.0 | 29.5 | 14.2 | 74.5 | 38.5 | 6.0/7.0 | 121.5 | 236.6 | 62.0 | 112.0/25178 |
| P100F189 | 100.0 | 60.0 | 28.8 | 14.0 | 70.0 | 38.0 | 6.5 | 122.0 | 278.0 | 62.0 | 200.0/44960 |
| P100F218 | 100.0 | 60.0 | 29.0 | 15.0 | 76.4 | 38.0 | 8.0 | 138.0 | 244.0 | 62.0 | 230.0/51704 |

橡胶手套输送链 Rubber gloves carrier chains

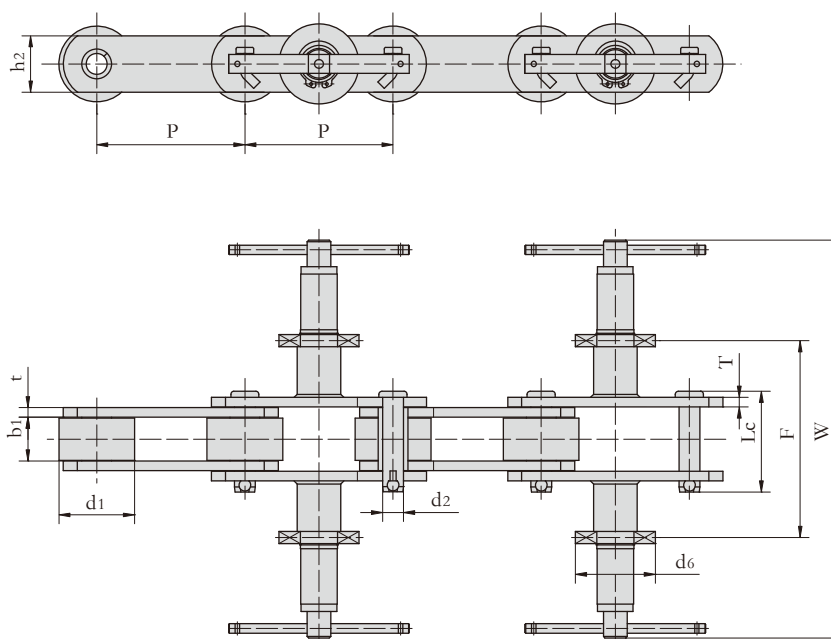

| 东华链号 Donghua Chain No. | 节距 | 滚子直径 | 内节内宽 | 销轴直径 | 销轴长度 | 链板高度 | 链板厚度 | 附件尺寸 | | | 抗拉强度 |
|------------------------------|-------|-----------------|----------------------------|--------------|------------|-------------|-----------------|-------|-------|------|------------------|
| | Pitch | Roller diameter | Width between inner plates | Pin diameter | Pin length | Plate depth | Plate thickness | F | W | d6 | Tensile strength |
| | p | d1 max | b1 min | d2 max | Lc max | h2 max | t/T max | mm | mm | mm | Q min |
| | mm | mm | mm | mm | mm | mm | mm | mm | mm | mm | kN/bf |
| P100F154 | 100.0 | 51.0 | 29.5 | 14.0 | 72.0 | 38.0 | 6.5 | 210.0 | 482.0 | 62.0 | 200.0/44960 |
| P100F170 | 100.0 | 60.0 | 29.5 | 16.0 | 72.0 | 45.0 | 6.5 | 207.0 | 480.0 | 62.0 | 260.0/58448 |
| P100F204 | 100.0 | 60.0 | 28.5 | 14.0 | 71.0 | 38.0 | 6.5 | 207.0 | 478.0 | 62.0 | 200.0/44960 |
| P100F310 | 100.0 | 60.0 | 28.0 | 16.0 | 72.0 | 40.0 | 7.0 | 199.0 | 478.0 | 62.0 | 200.0/44960 |
| P100F312 | 100.0 | 58.0 | 28.5 | 16.0 | 77.0 | 40.0 | 8.0 | 207.0 | 478.0 | 62.0 | 260.0/58448 |
| P100F335 | 100.0 | 60.0 | 28.5 | 16.0 | 77.0 | 40.0 | 8.0 | 207.0 | 478.0 | 62.0 | 260.0/58449 |

橡胶手套输送链 Rubber gloves carrier chains

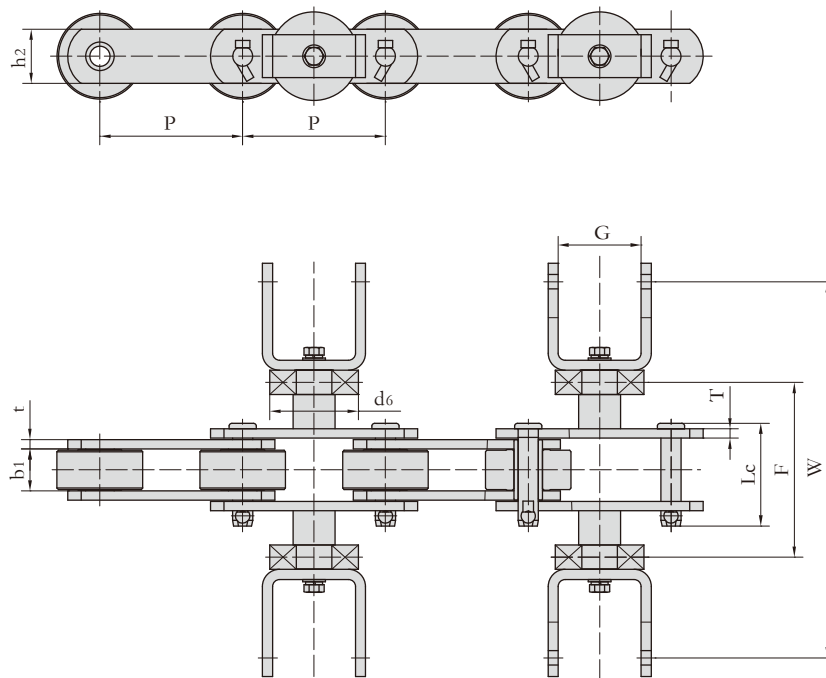

| 东华链号 Donghua Chain No. | 节距 | 滚子直径 | 内节内宽 | 销轴直径 | 销轴长度 | 链板高度 | 链板厚度 | 附件尺寸 | | | | 抗拉强度 |
|------------------------------|-------|-----------------|----------------------------|--------------|------------|-------------|-----------------|----------------------|-----|----|------|------------------|
| | Pitch | Roller diameter | Width between inner plates | Pin diameter | Pin length | Plate depth | Plate thickness | Attachment dimension | | | | Tensile strength |
| | p | d1 max | b1 min | d2 max | Lc max | h2 max | t/T max | F | W | d6 | G | Q min |
| | mm | mm | mm | mm | mm | mm | mm | mm | mm | mm | mm | kN/bf |
| P100F155 | 100 | 60 | 29.5 | 14 | 72 | 38 | 6.5 | 122 | 262 | 62 | 59.5 | 200.0/44960 |
| P100F190* | 100 | 60 | 28.5 | 14 | 71 | 38 | 6.5 | 121 | 262 | 62 | 58.5 | 200.0/44960 |
| P100F205 | 100 | 60 | 29.5 | 14 | 71 | 38 | 6.5 | 121 | 263 | 62 | 58.2 | 200.0/44960 |
| P100F328* | 100 | 60 | 28.5 | 14 | 71 | 38 | 6.5 | 121 | 222 | 62 | 58.5 | 200.0/44960 |

*表示U型附板带加强筋

*U Type attachment with reinforce rib